

model Kartonowy



1 : 200

# MODELNIK

# CZKAŁOWY

RADZIECKI LEKKI KRAŻOWNIKI Z 1950 ROKU

Rok XIII (XX)

Nr 19/09

ISSN 1428-3840

Nakład 1000 egz.



SPANKO



# CZ KAIFLOW

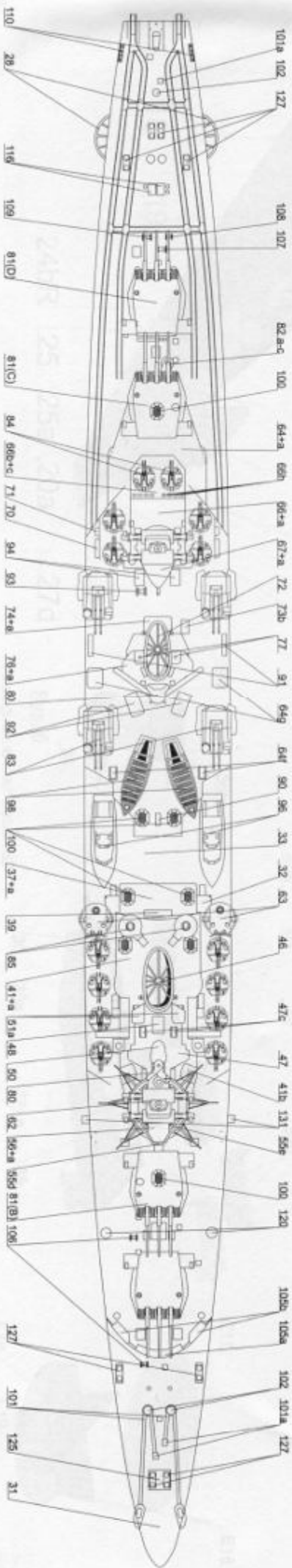
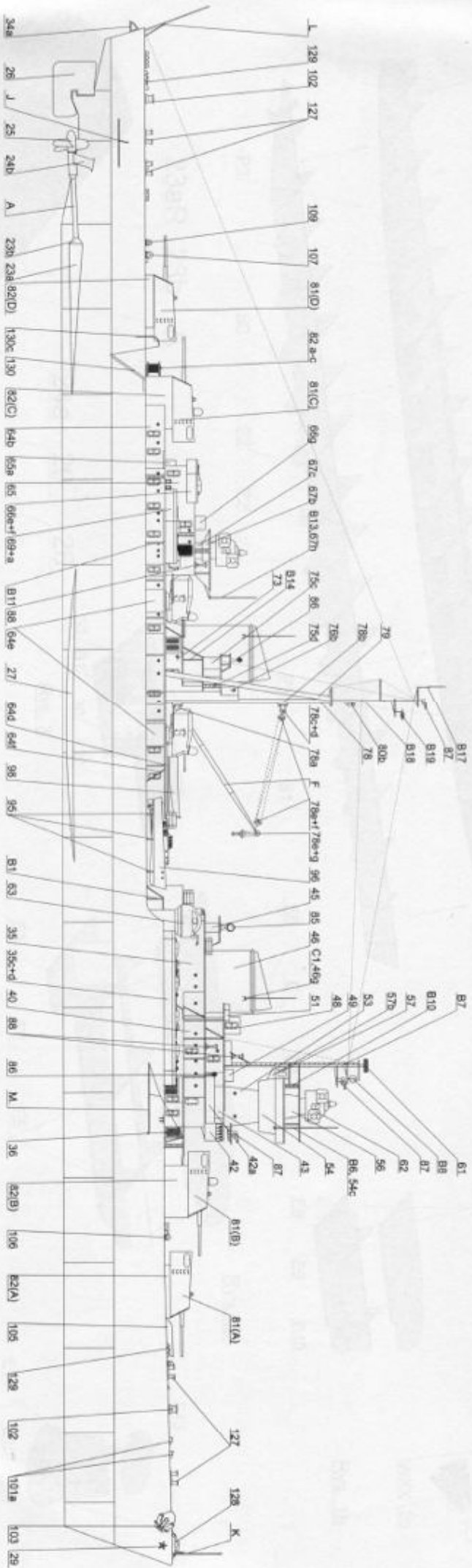

Rvs. 2

Rev. 5

3-1-45

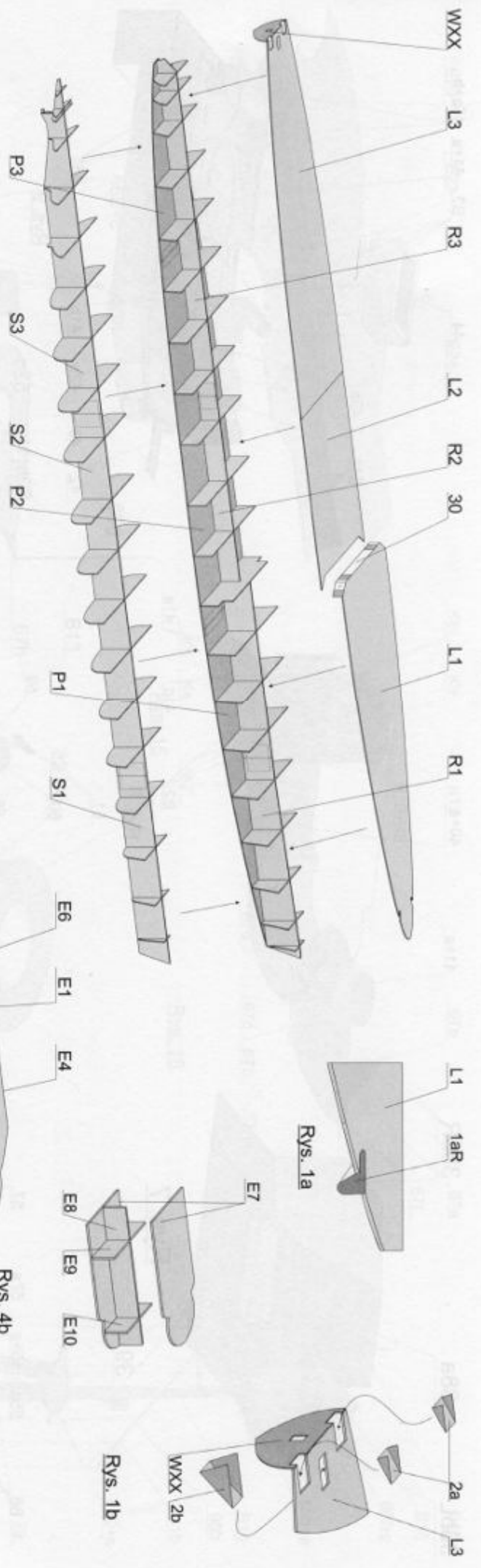

Rys. 1

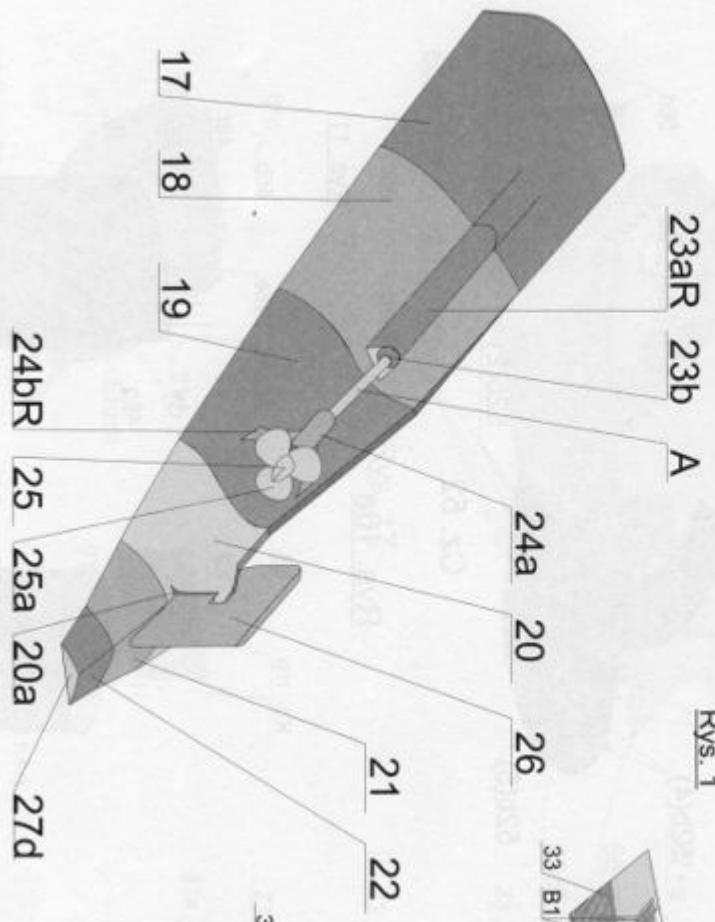

Rys. 2

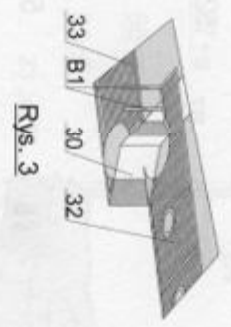

Rys. 3

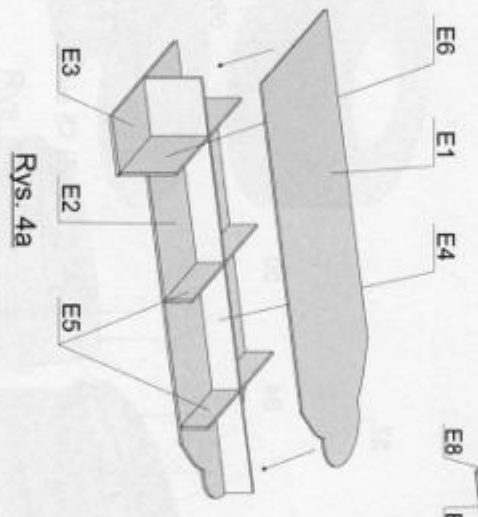

Rys. 4a

Rys. 4b

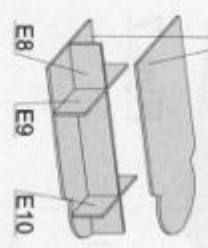

Rys. 1b

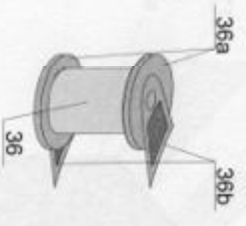

Rys. 6

Analogicznie klejć bębny 82

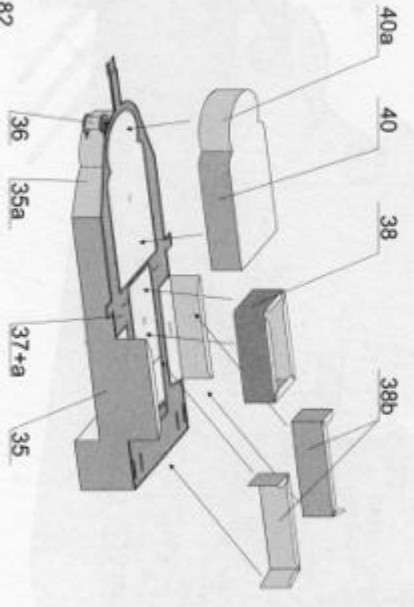

Rys. 5

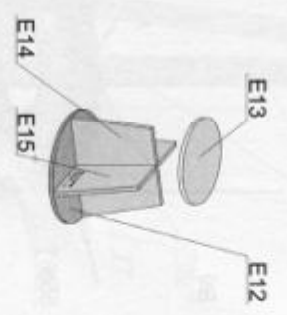

Rys. 4c

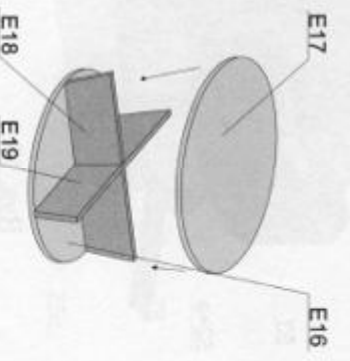

Rys. 4d

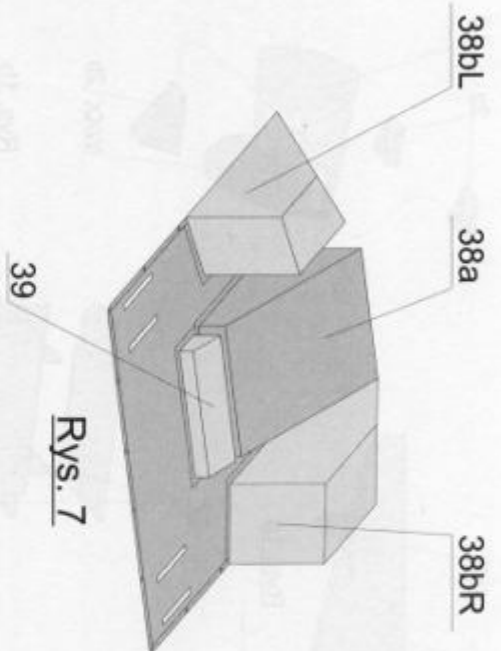

Rys. 7

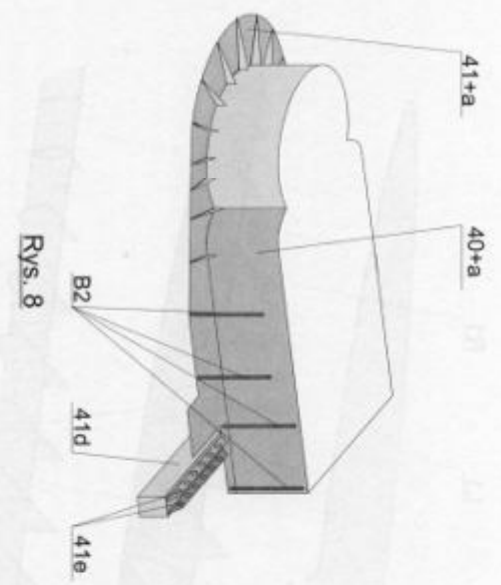

Rys. 8

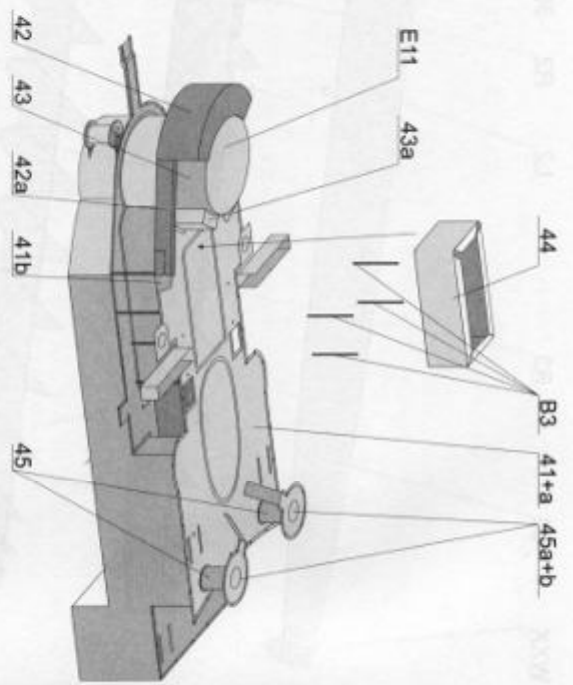

Rys. 9

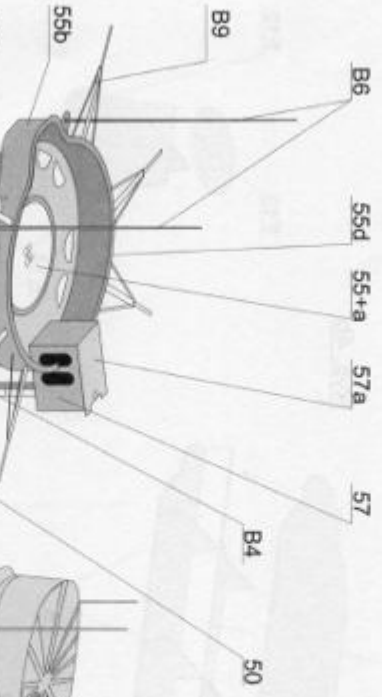

Rys. 10

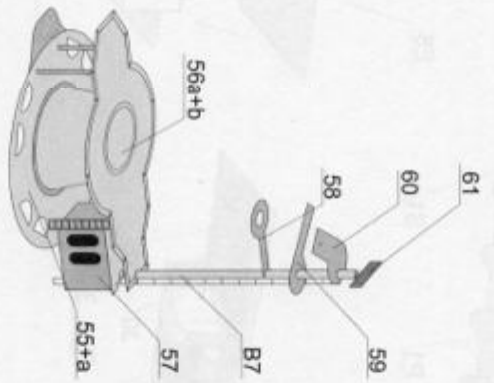

Rys. 12

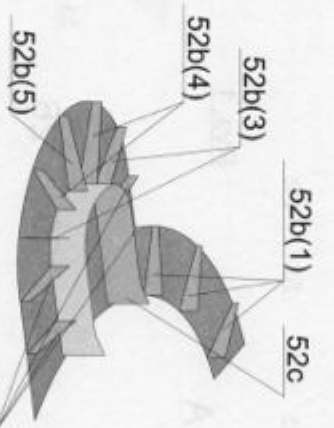
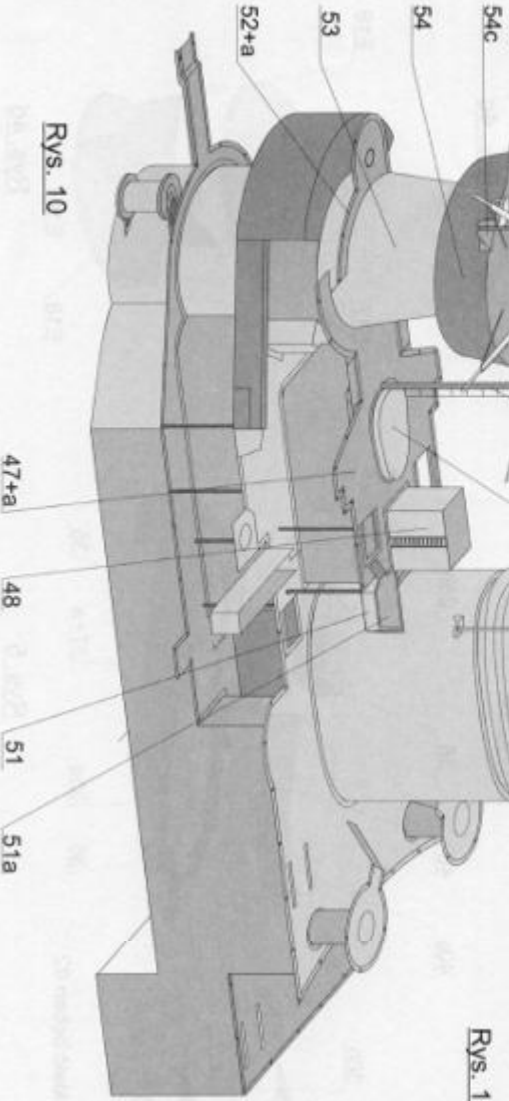

Cz. 52

Rys. 10a

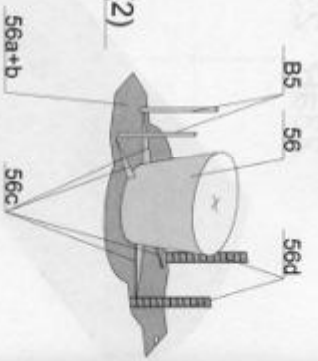

Rys. 11

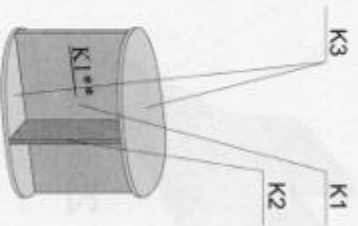

Rys. 13

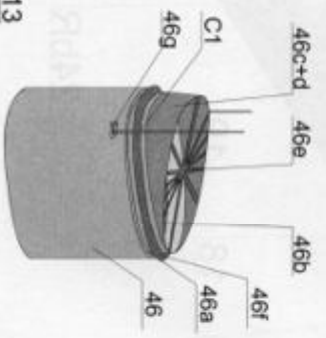

Analogiczne kleńc komlin cz. 72

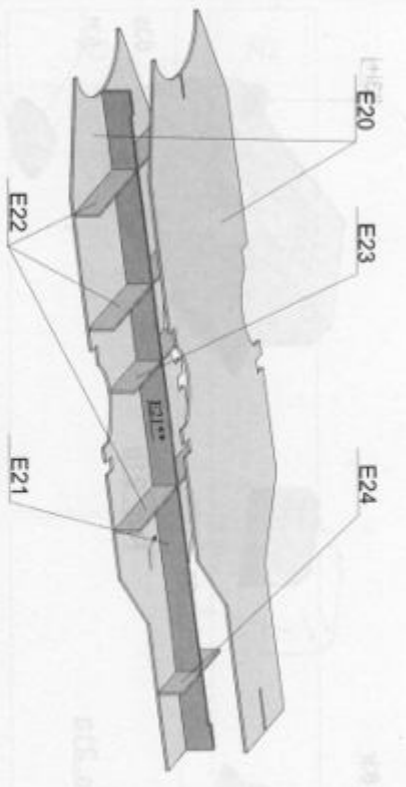

Rys. 14

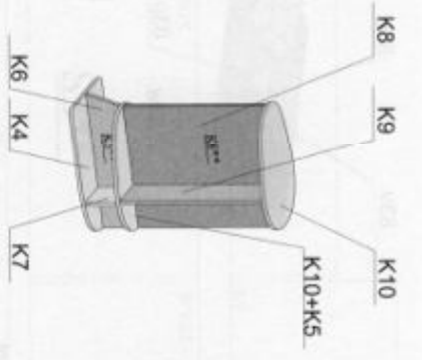

Rys. 15

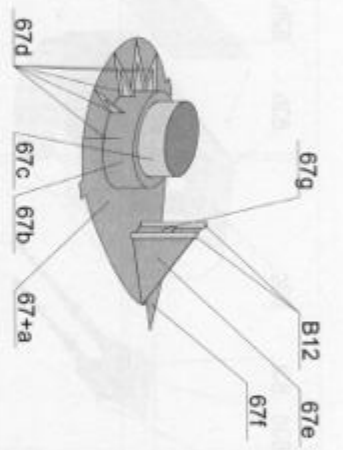

Rys. 18

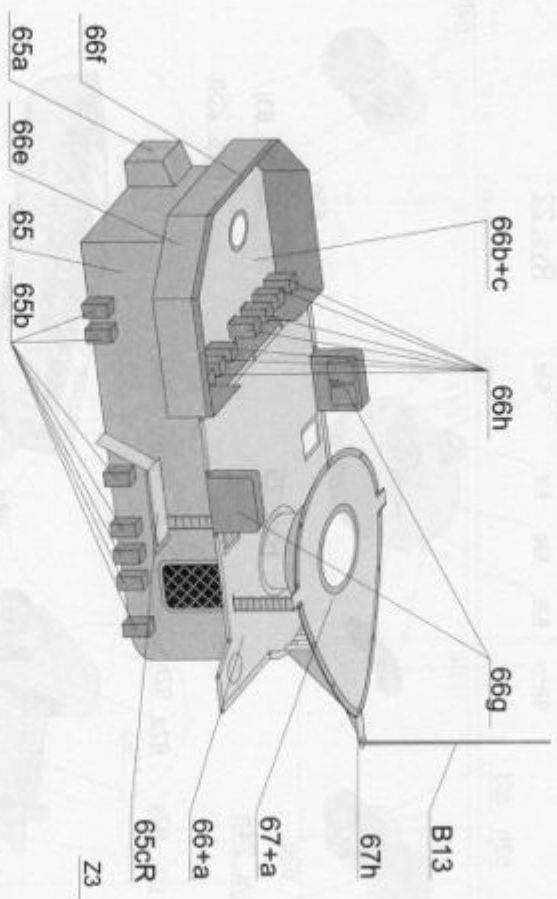

Rys. 17

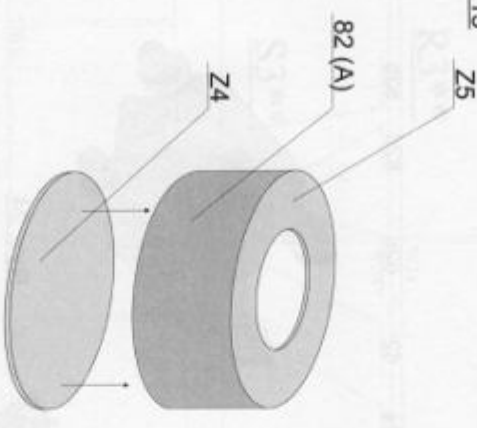

Analogicznie 82 (B, C, D)

Rys. 19a

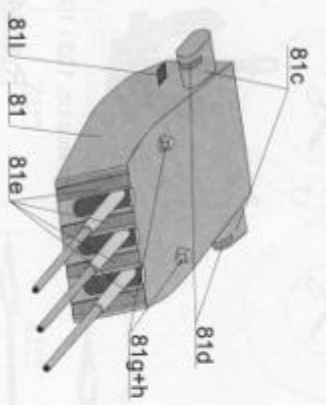

Rys. 20

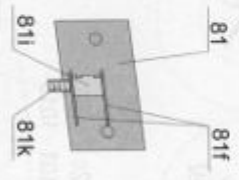

Rys. 20a

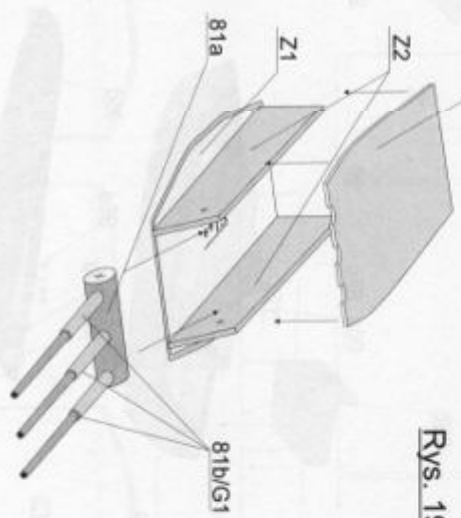

Rys. 19

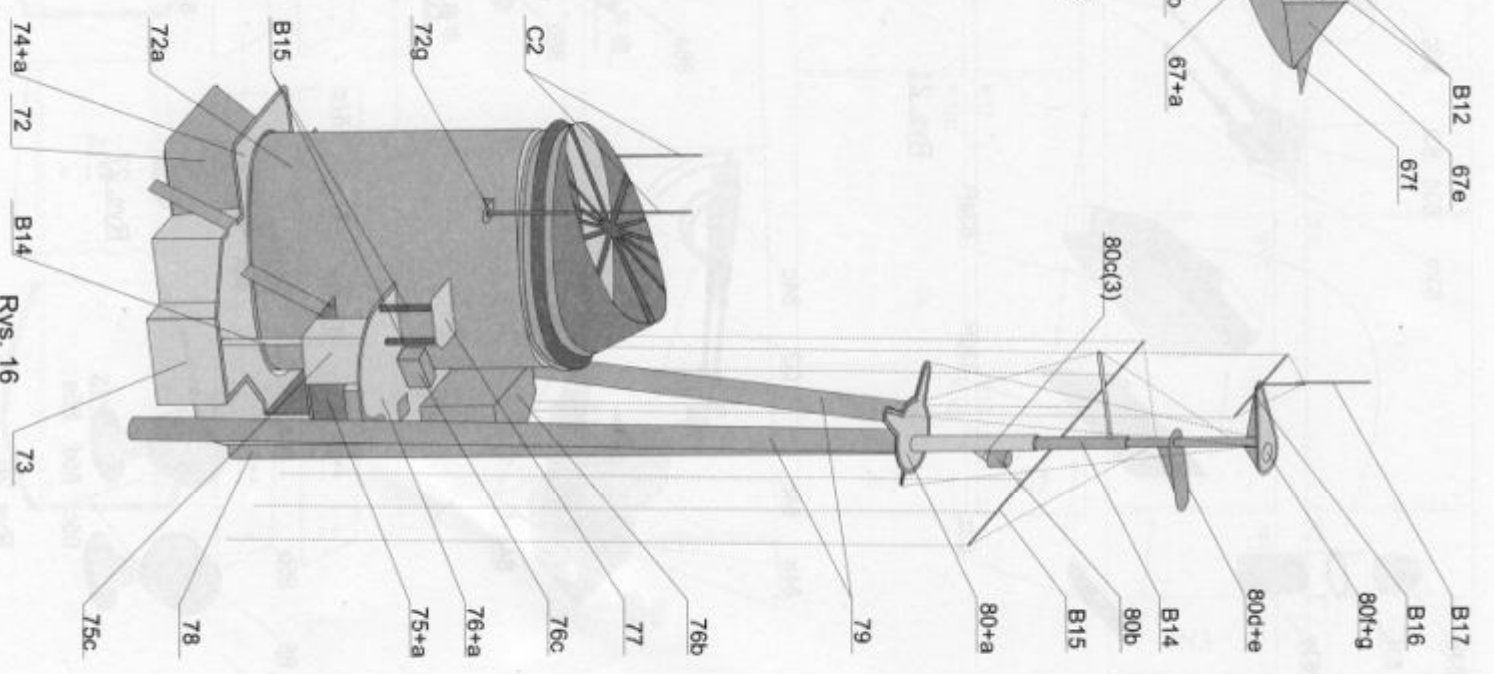

Rys. 16

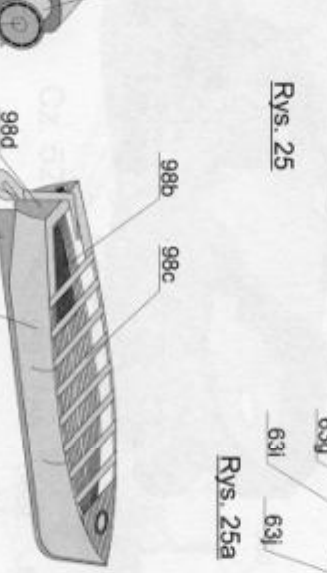
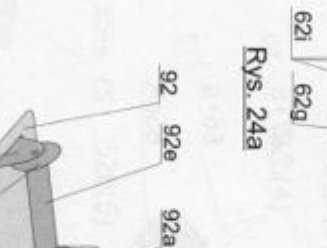
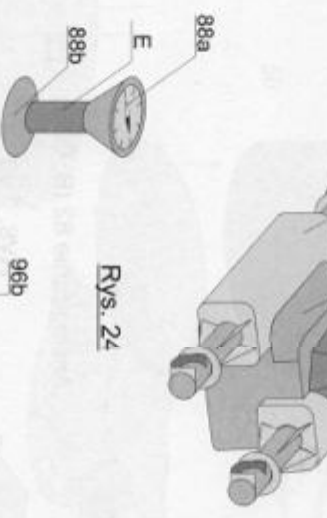
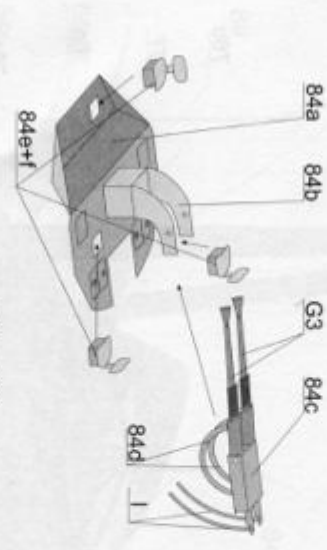
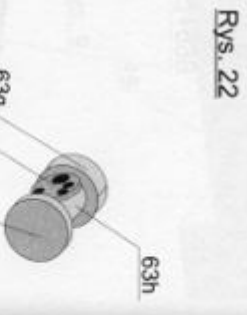
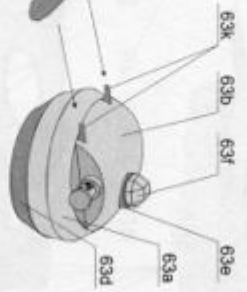
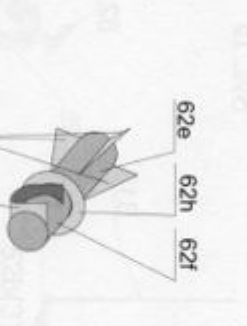
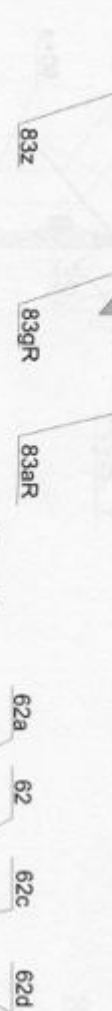
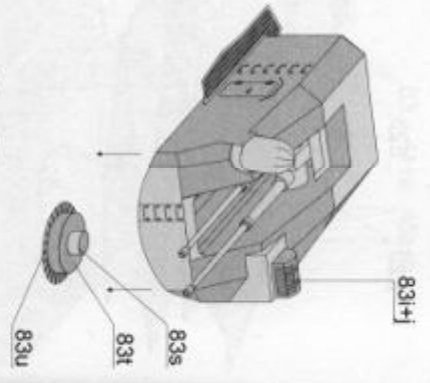
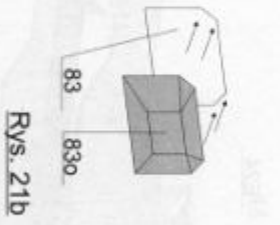
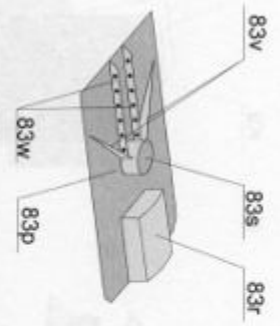
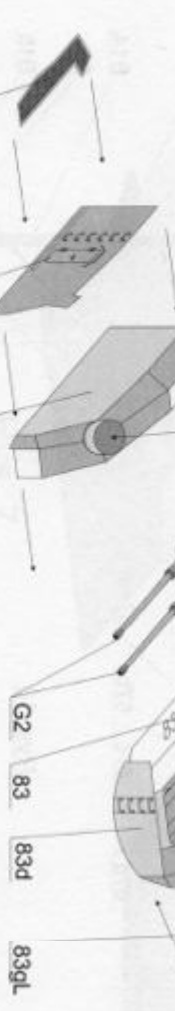
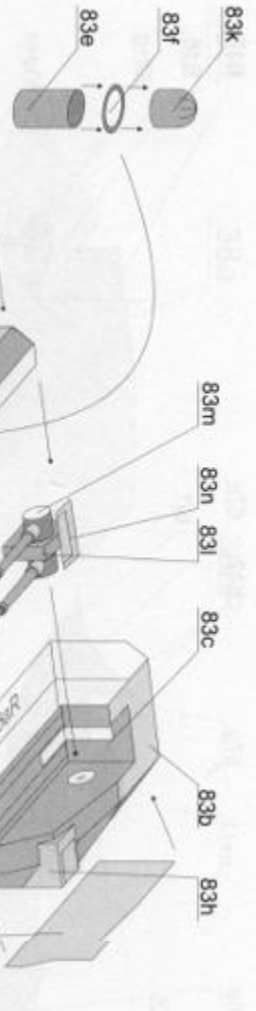

Rys. 23

Rys. 28

Rys. 24

Rys. 30

Rys. 31

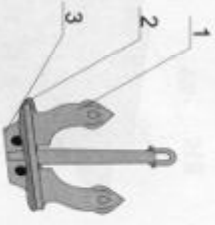
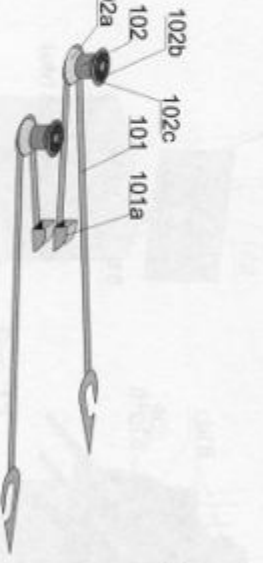
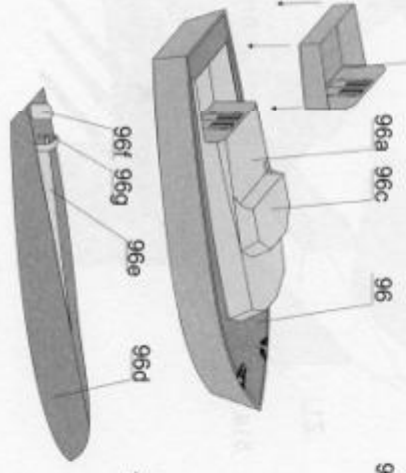
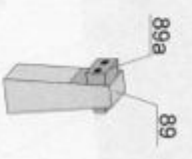
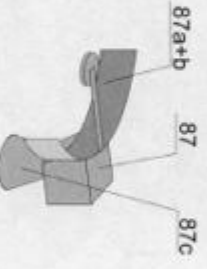
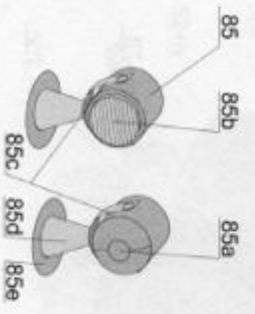

Rys. 26

Rys. 27

Rys. 29

Rys. 32

Rys. 33

Rys. 34

Kowlica cz. 103 i 104

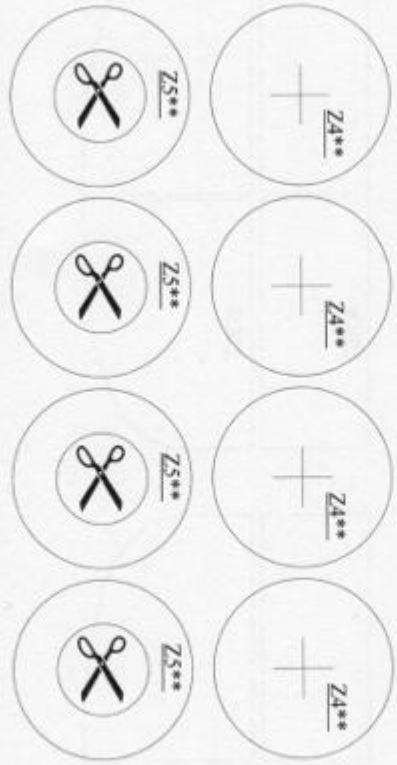
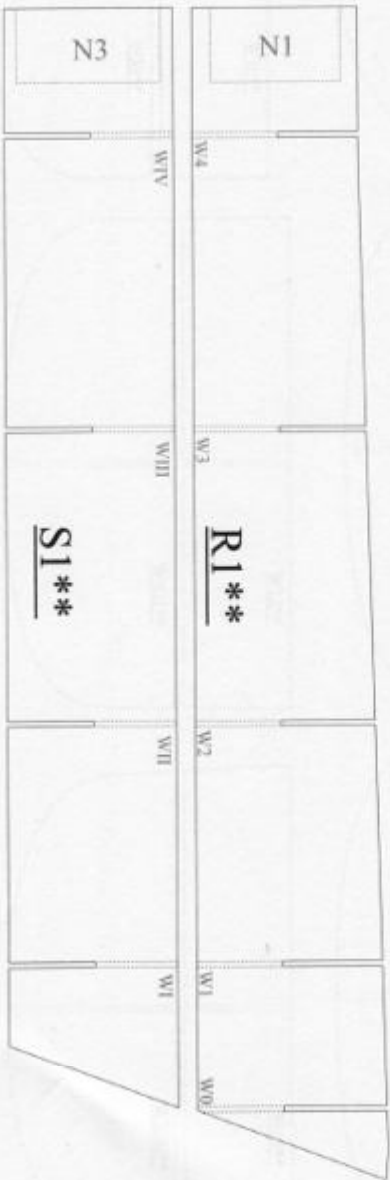

Zaszlifować

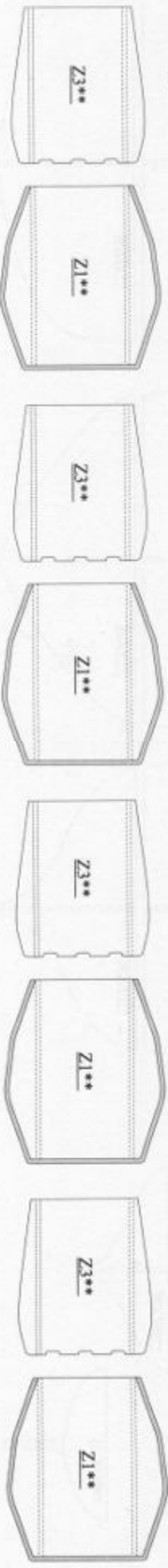



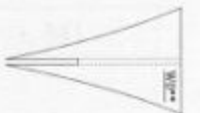

W101\*\*

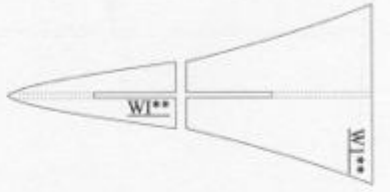

W102\*\*

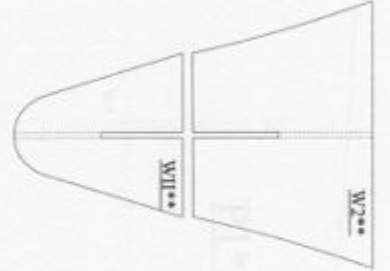

W103\*\*

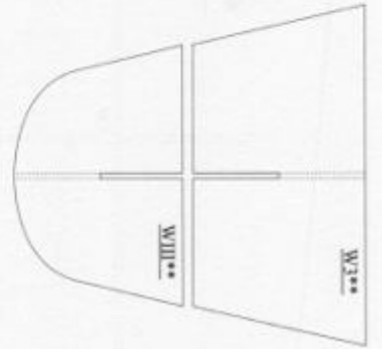

W104\*\*



W105\*\*



W106\*\*

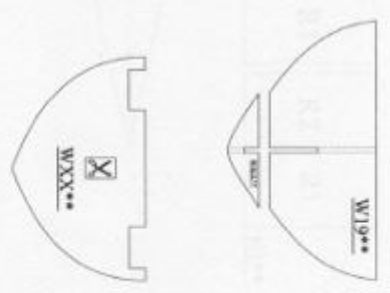

W107\*\*



W108\*\*

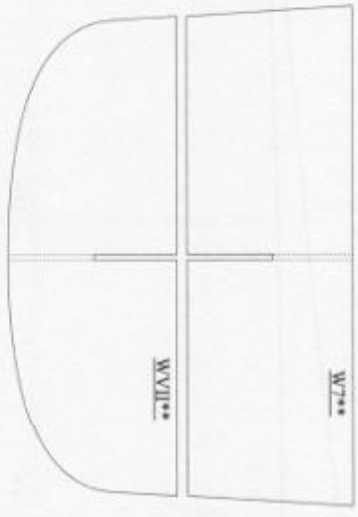

W109\*\*

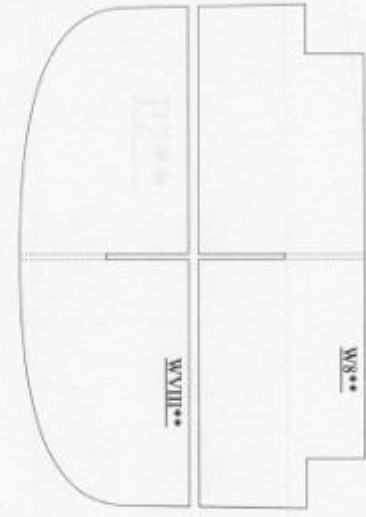

W110\*\*

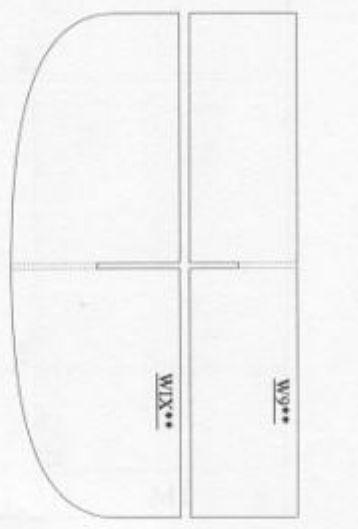

W111\*\*

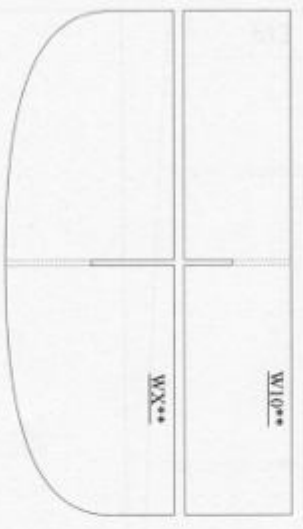

W112\*\*

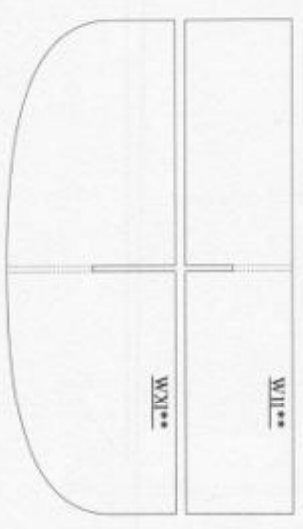

W113\*\*

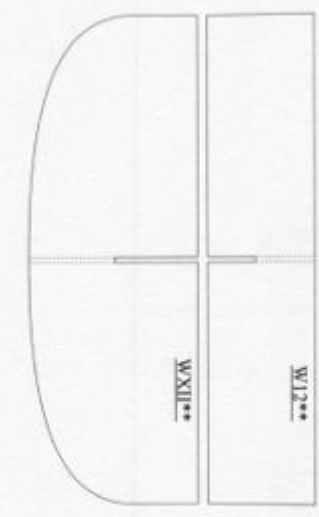

W114\*\*

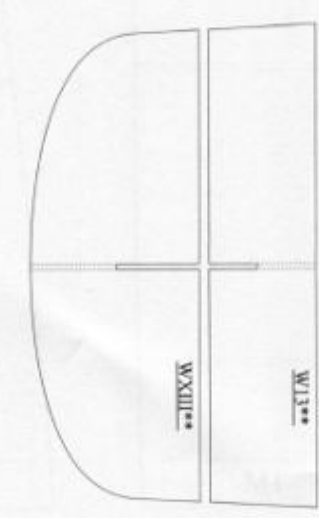

W115\*\*

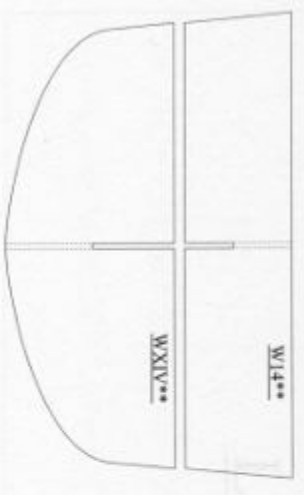

W116\*\*

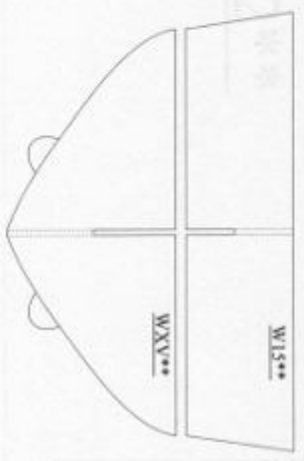

W117\*\*

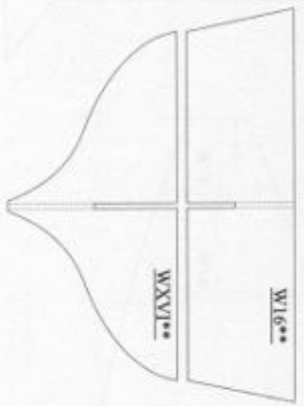

W118\*\*

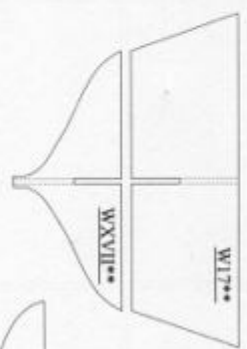

W119\*\*

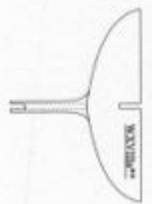

W120\*\*



W121\*\*

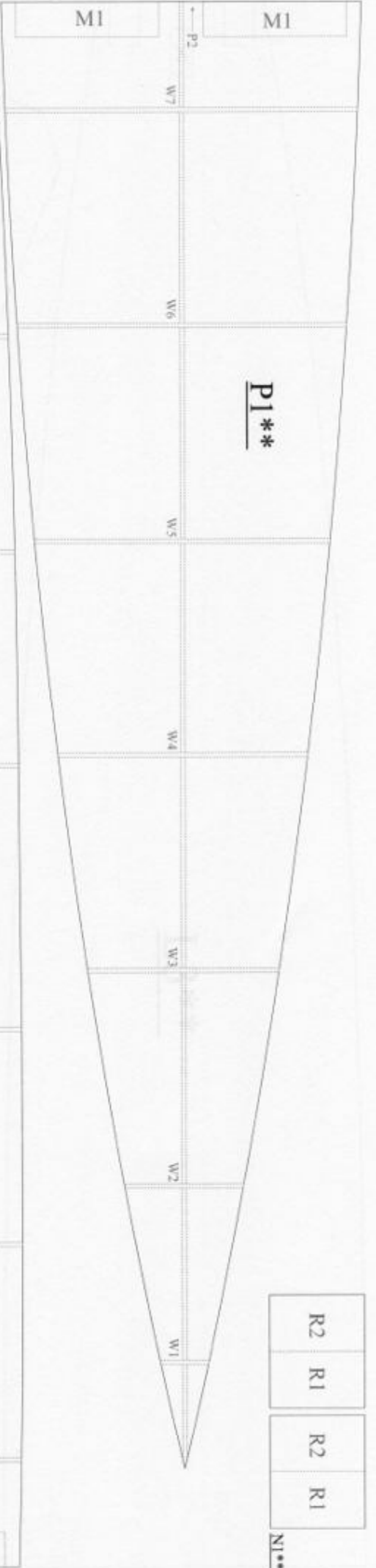
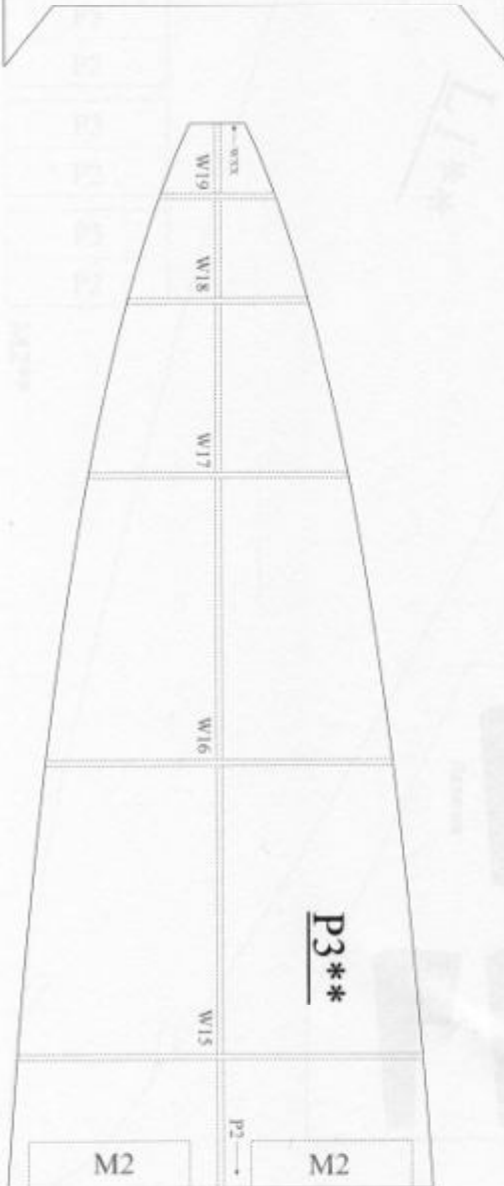

X

L3\*\*

R3	R2
R3	R2

N2\*\*

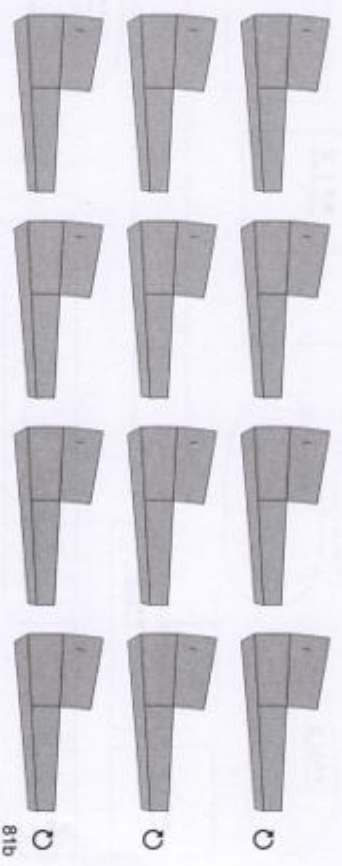

L1\*\*

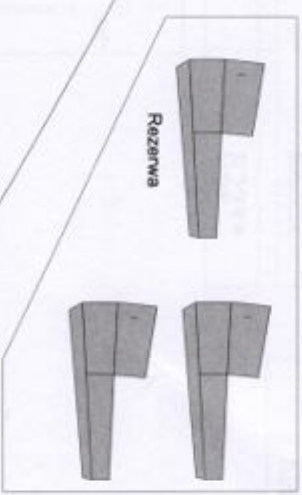

N3\*\*

S2	S3
S2	S1

S2	S3
----	----

M1\*\*

P2
P1

P2
P1

P2
P1

P2
P1

P3
P2

P3
P2

P3
P2

P3
P2

M2\*\*

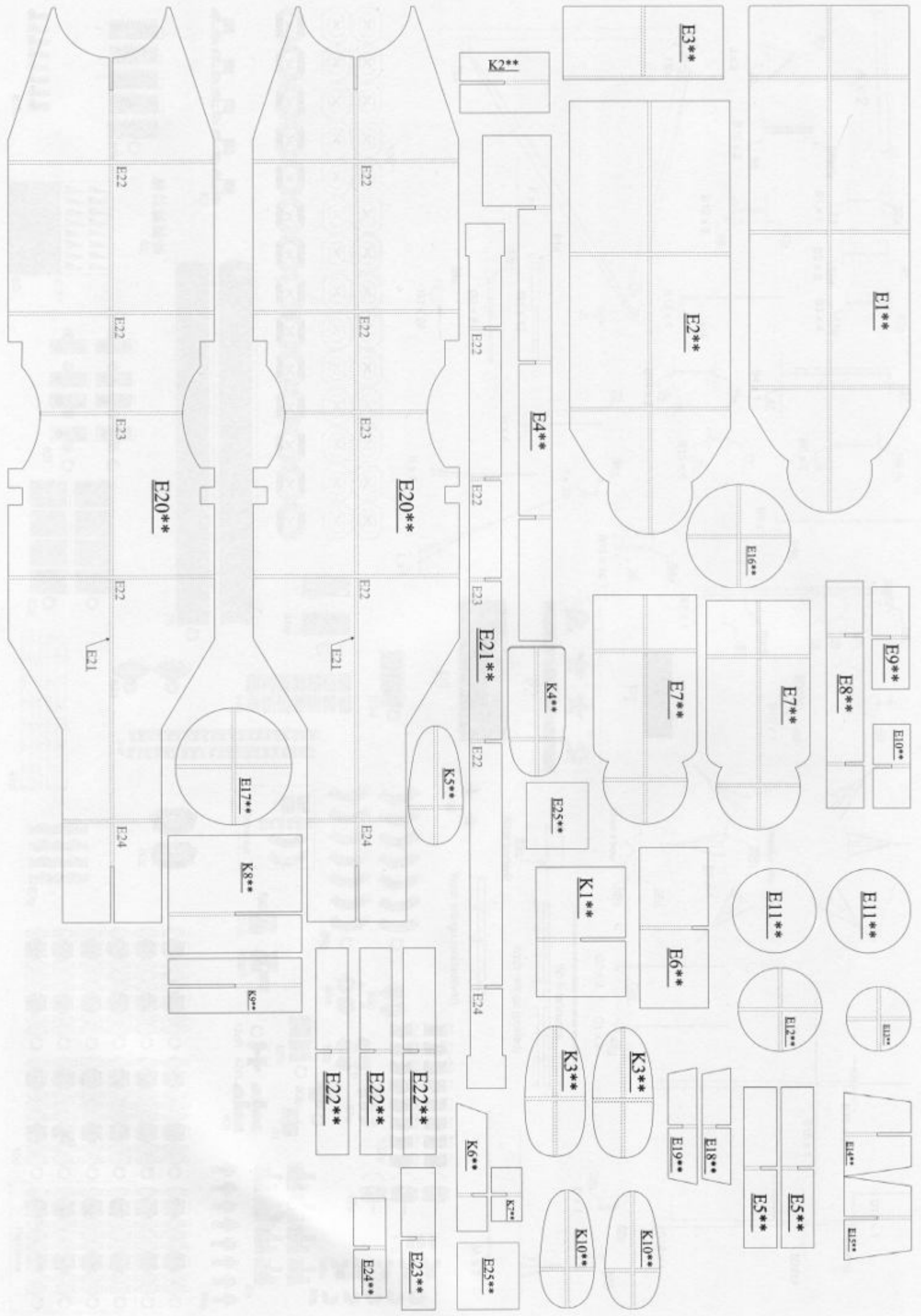





100a

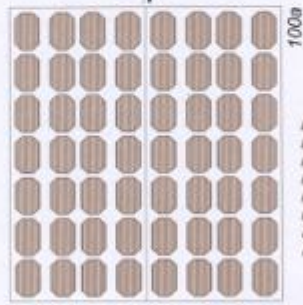
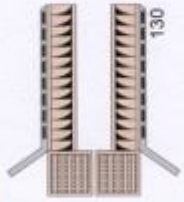
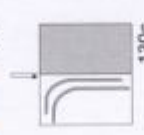
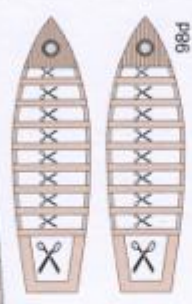
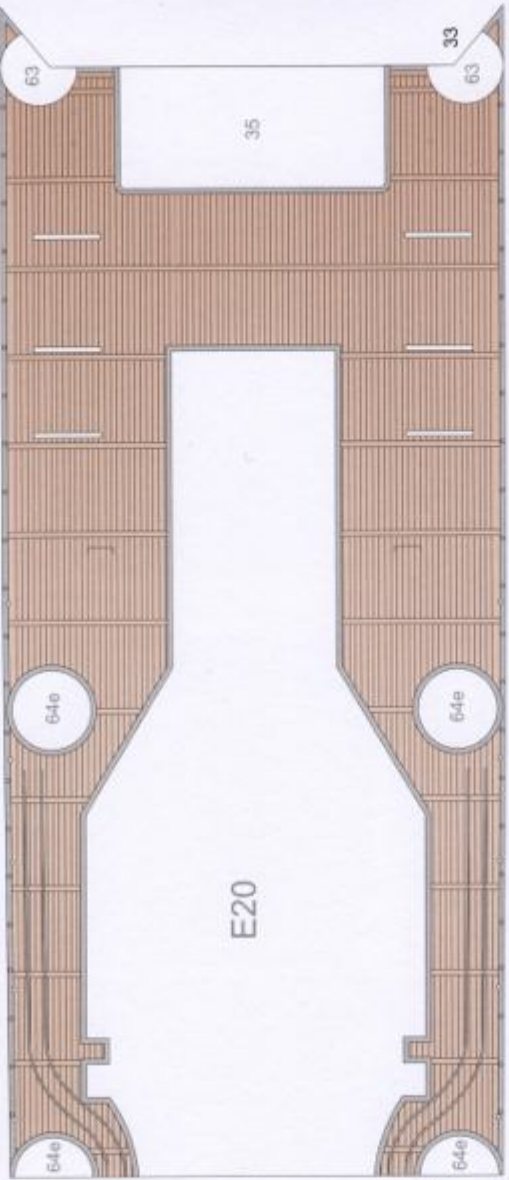
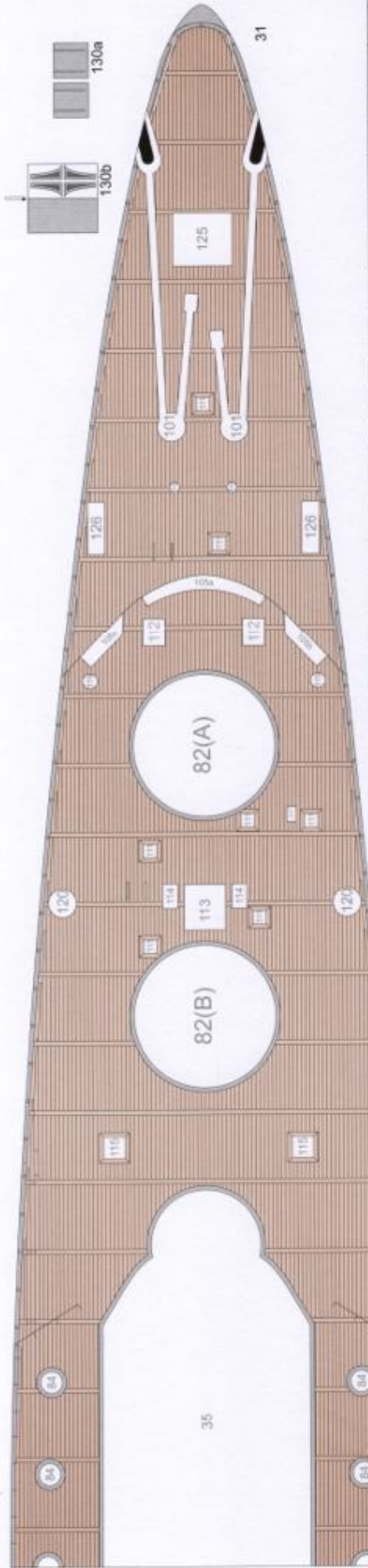

100a

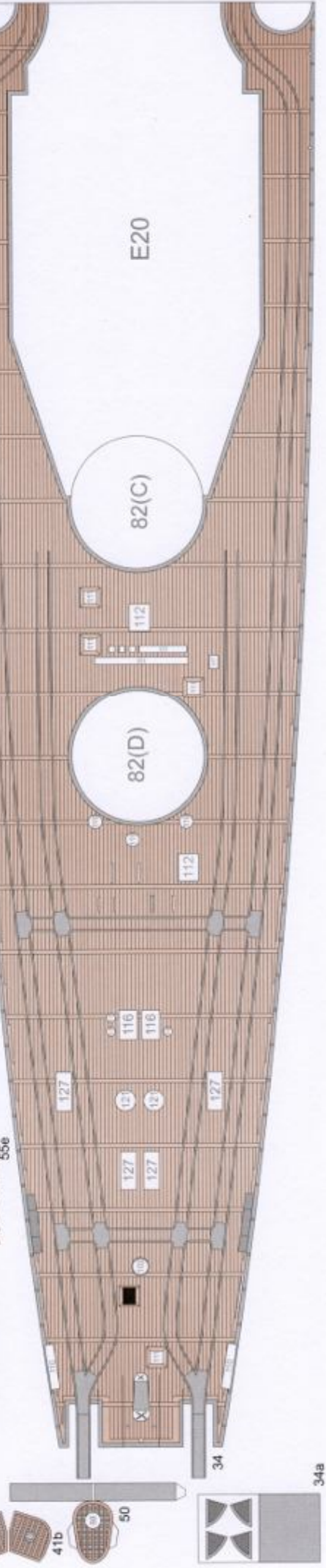
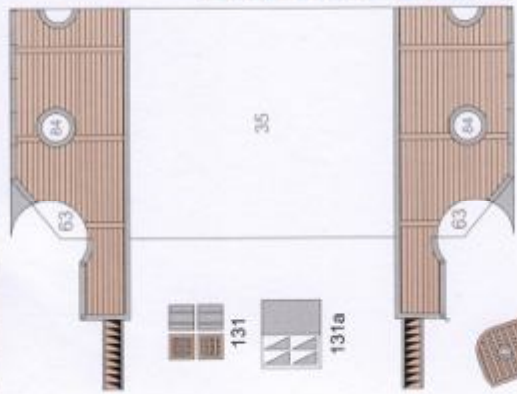

34B

REZERWA



12  
↑ ↓  
REZERWA

7 REZERWA  
↑ ↓

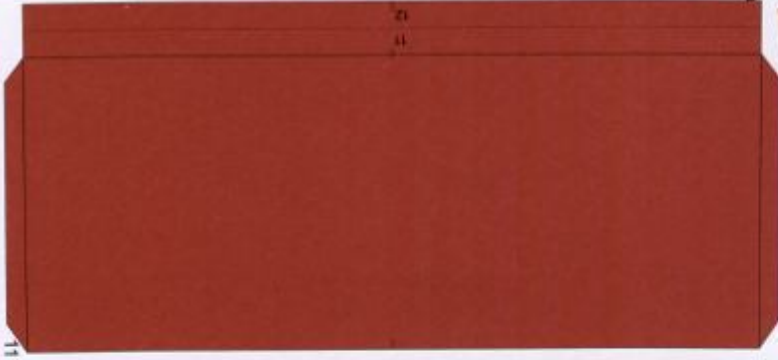

REZERWA

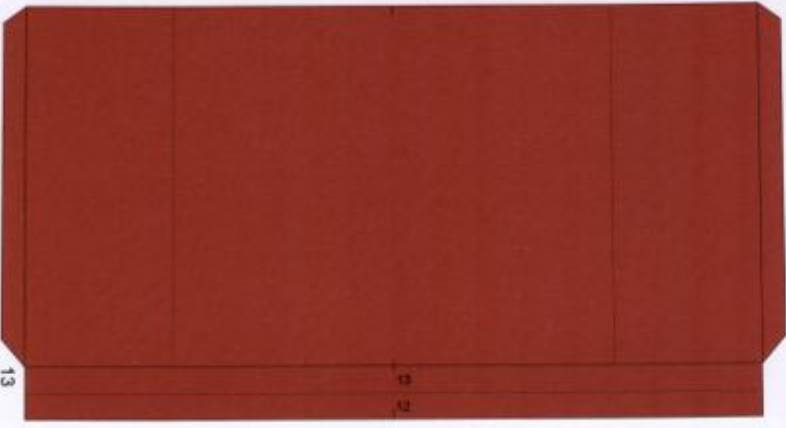

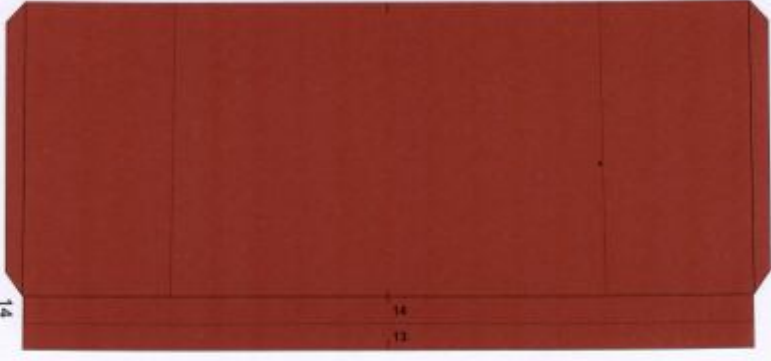
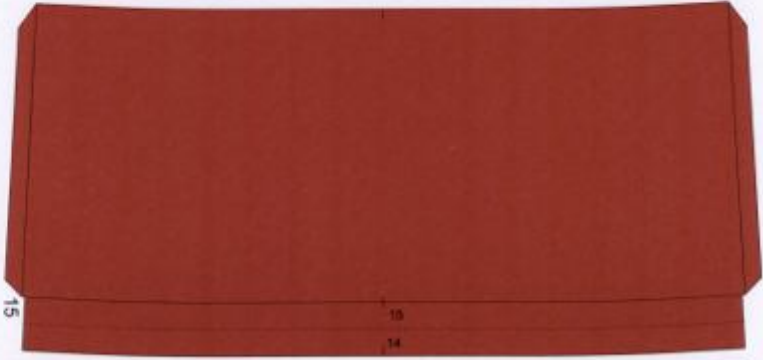
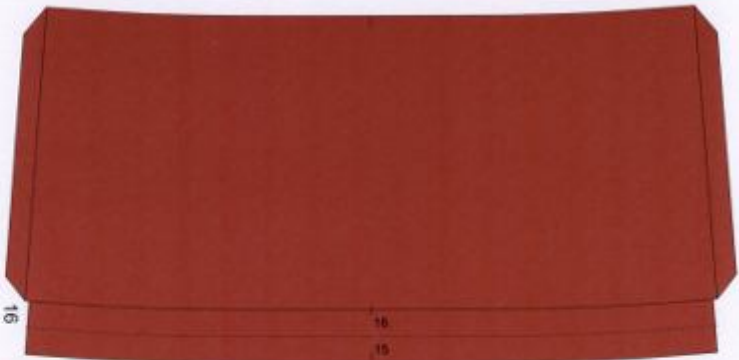

REZERWA

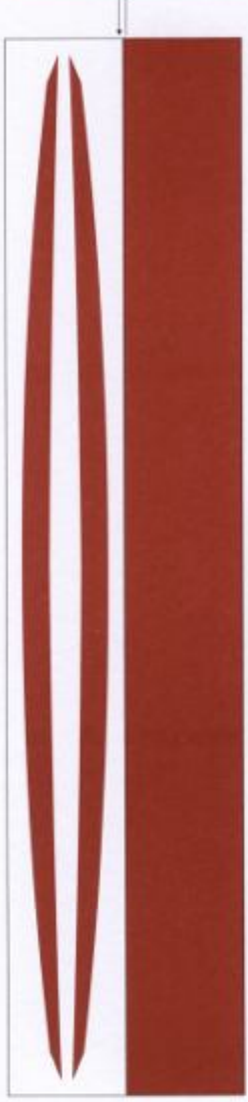
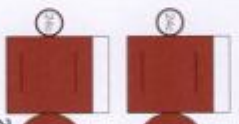



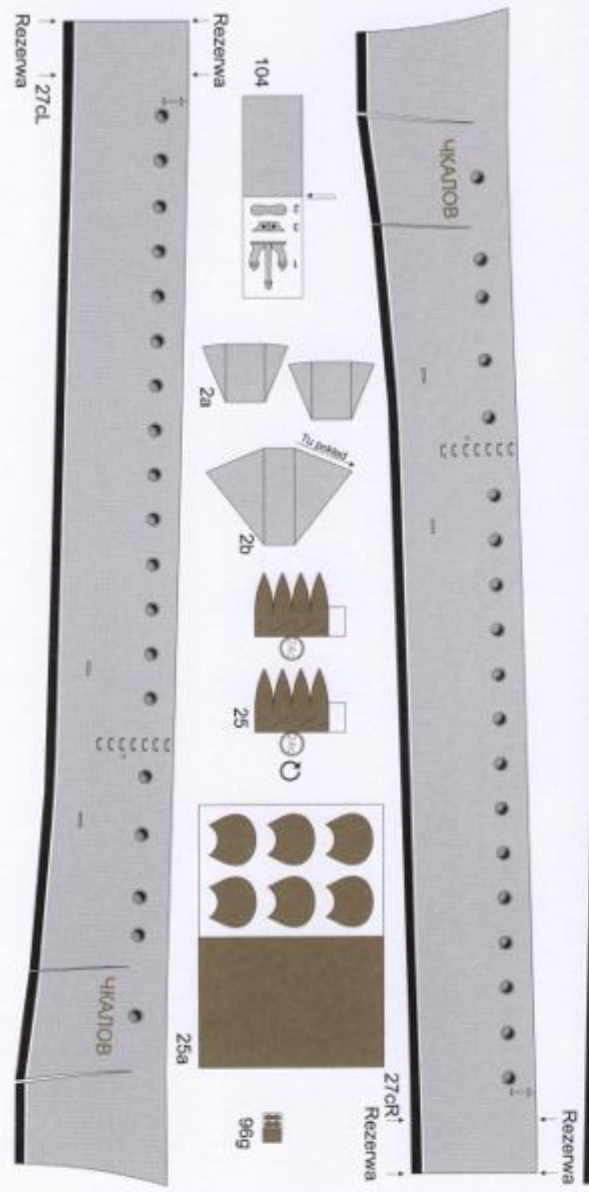
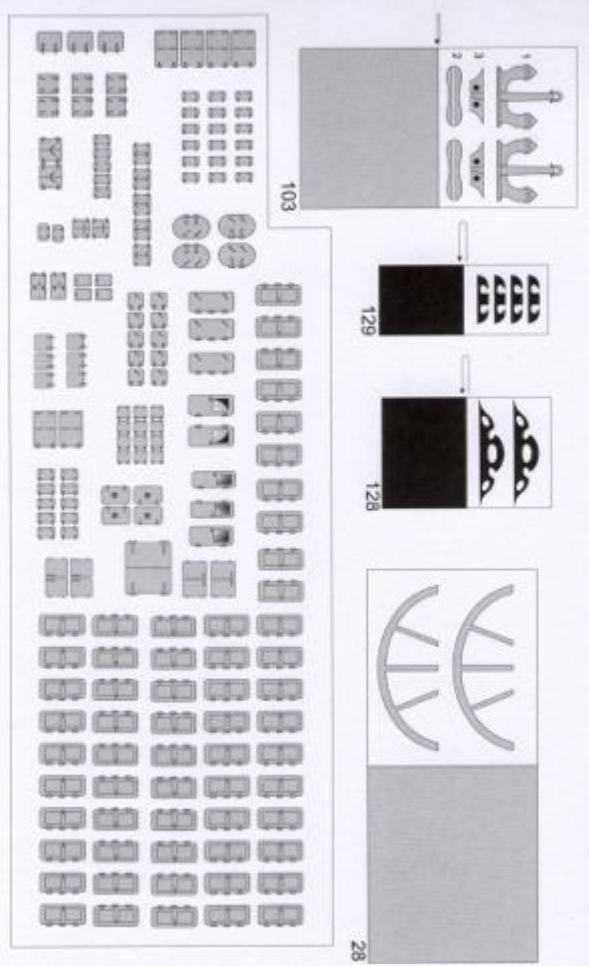
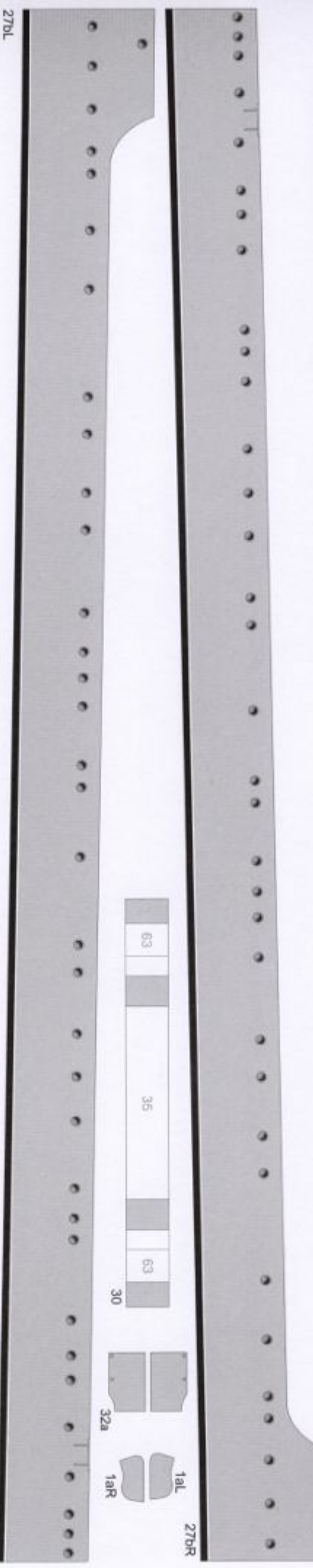

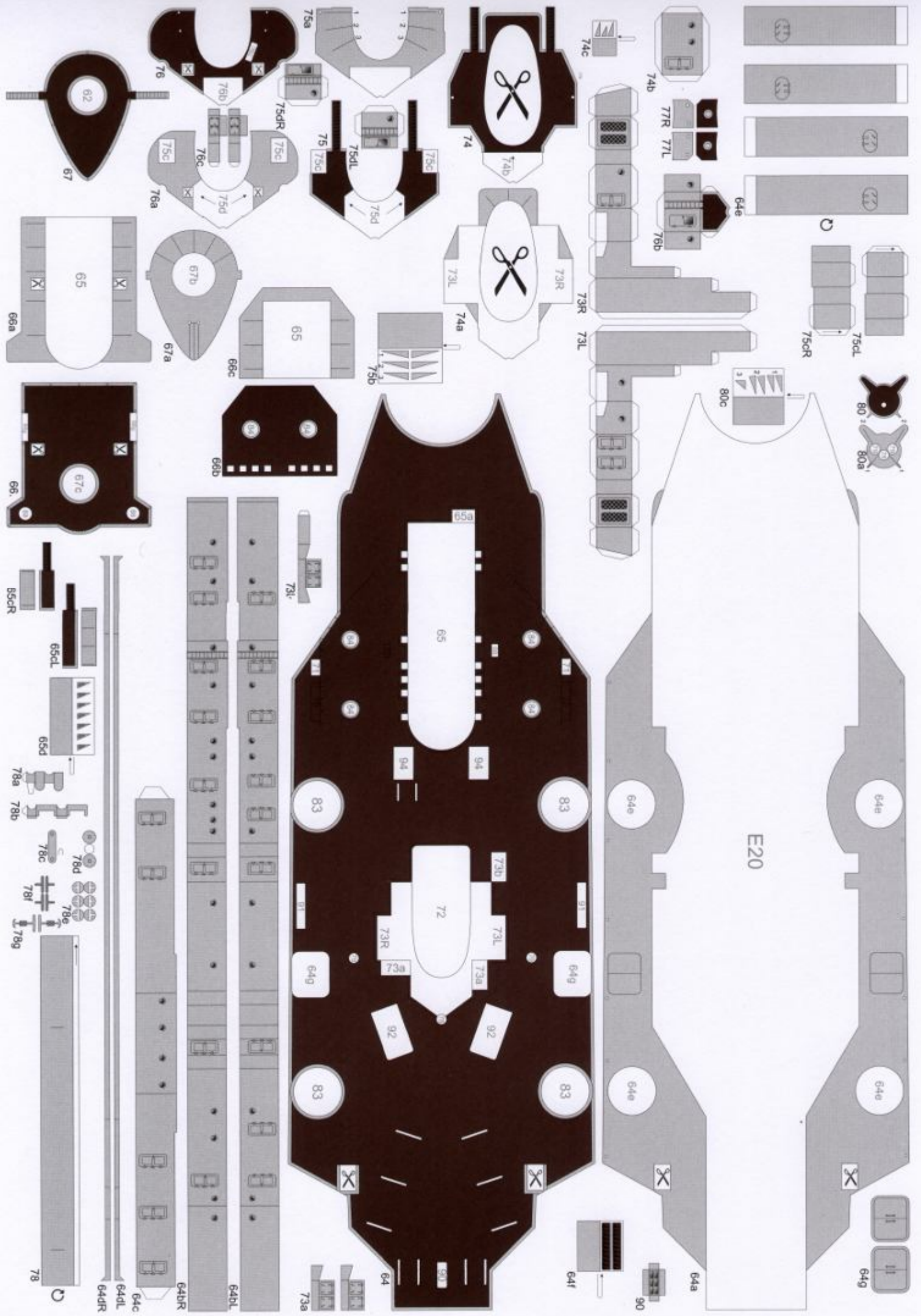

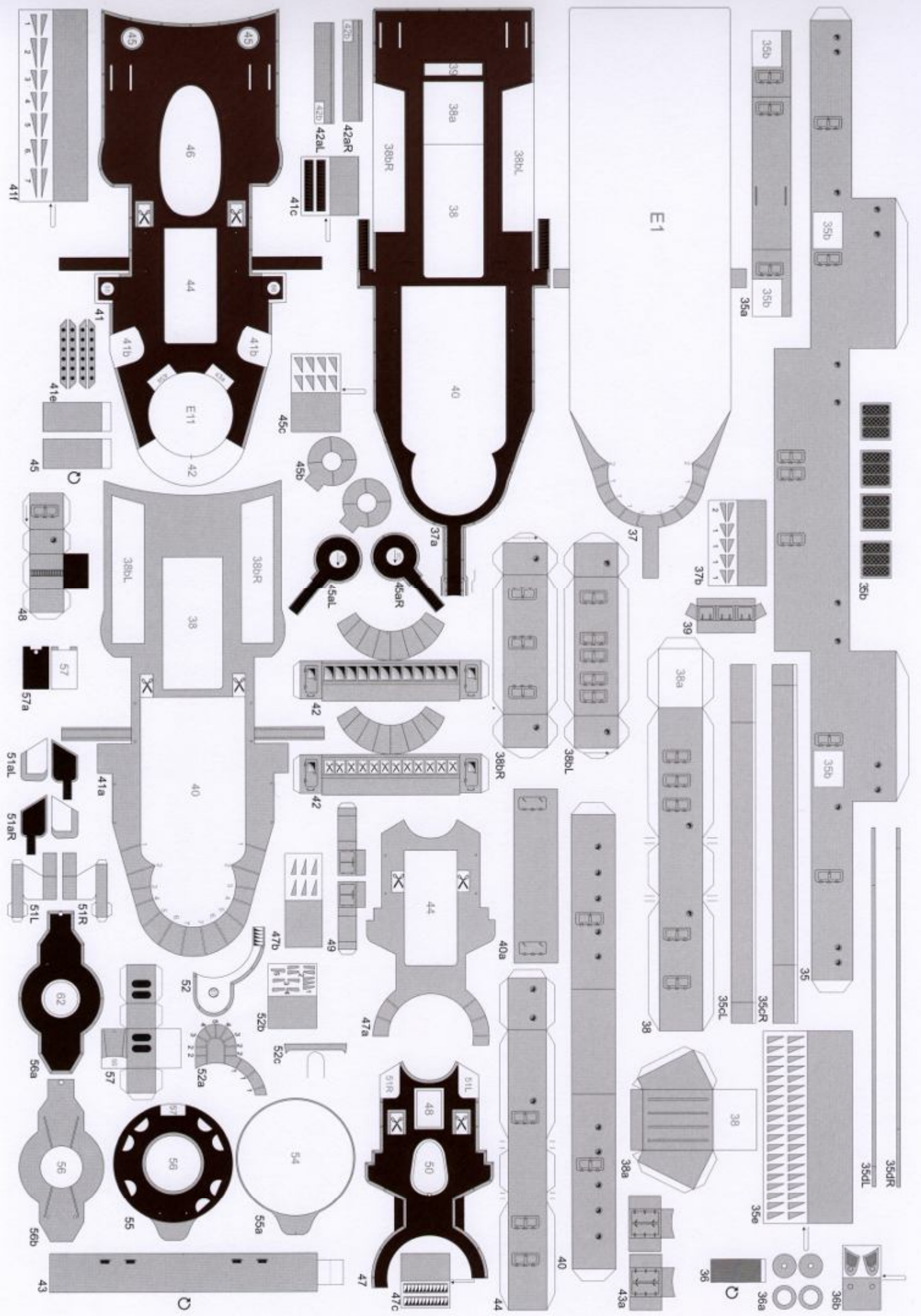

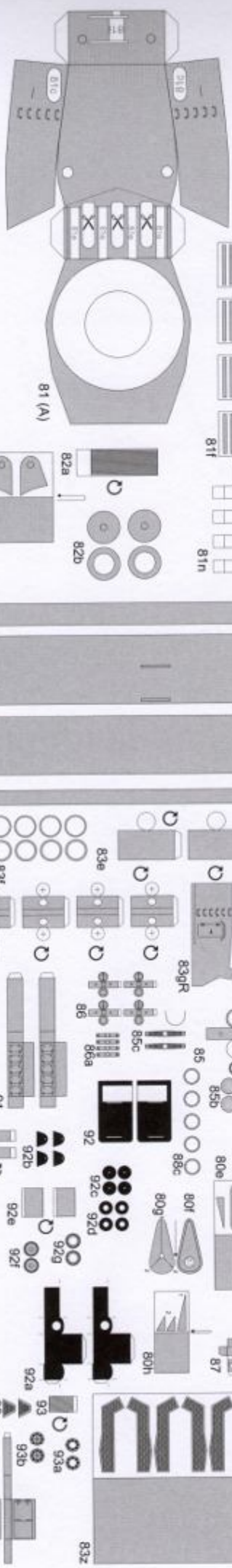
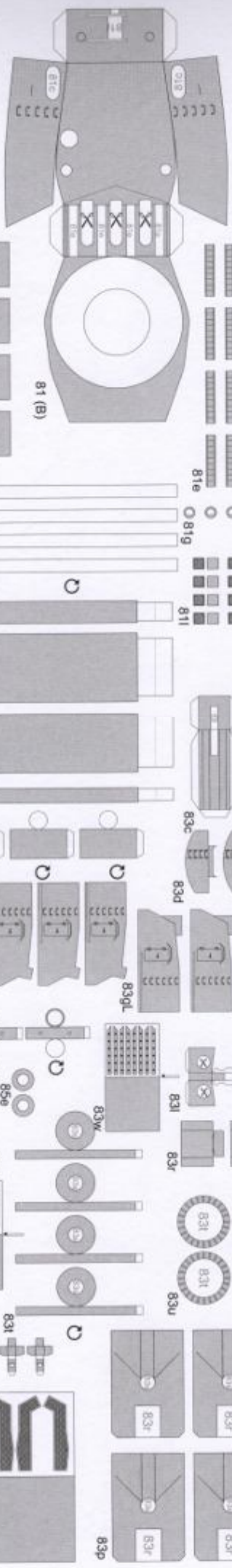
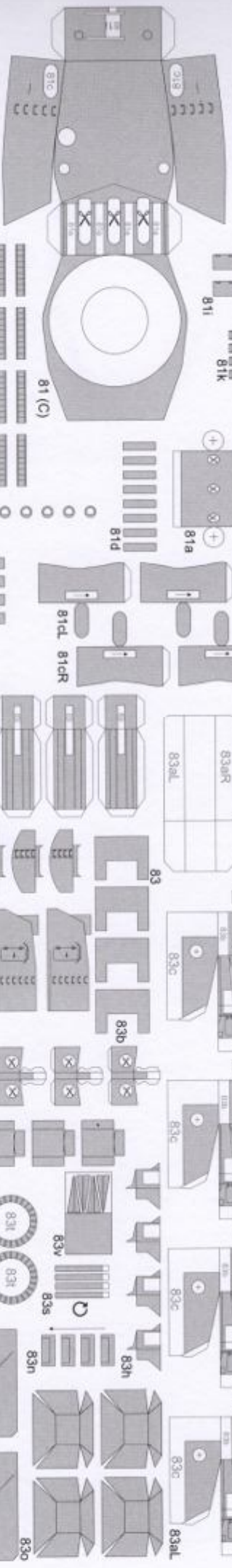

REZERWA

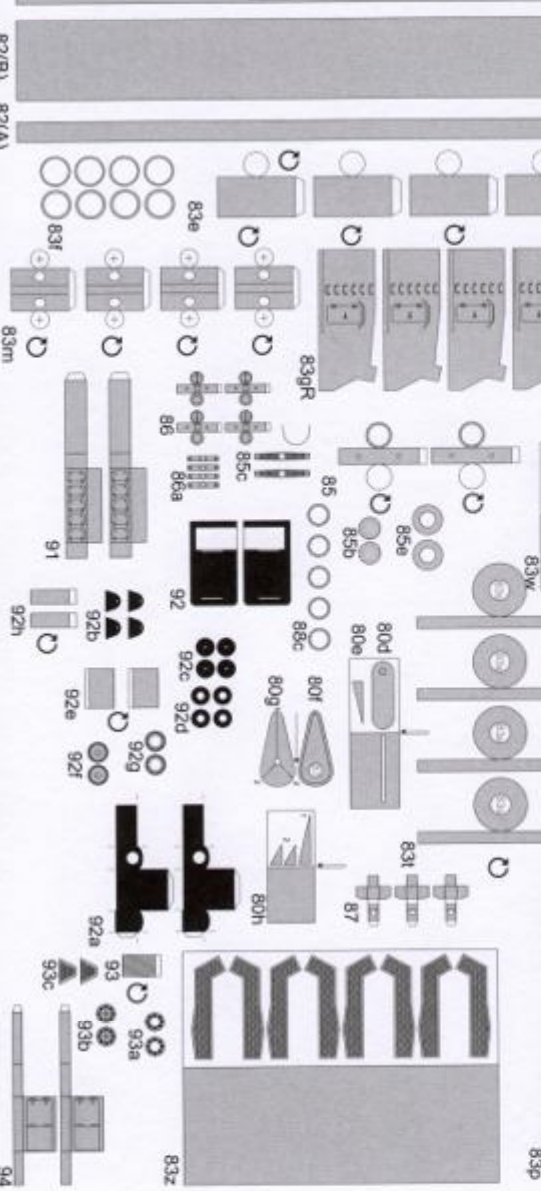
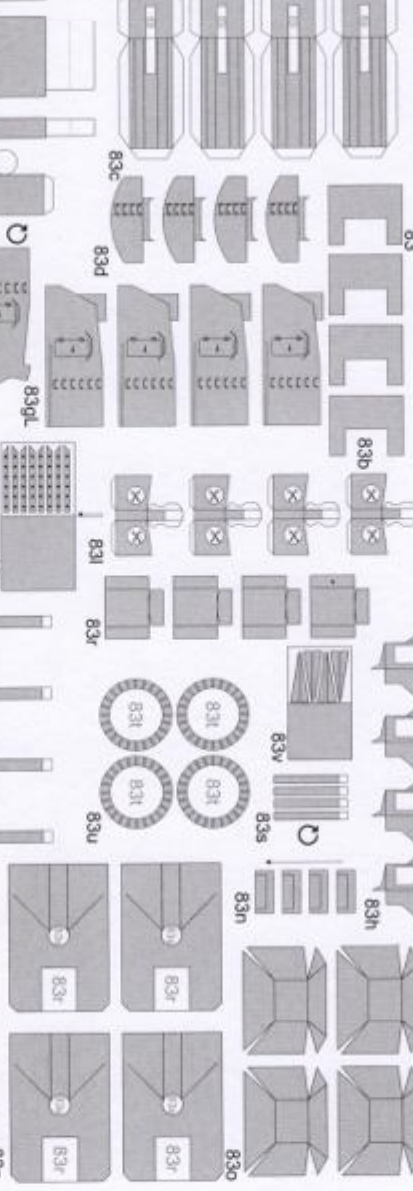
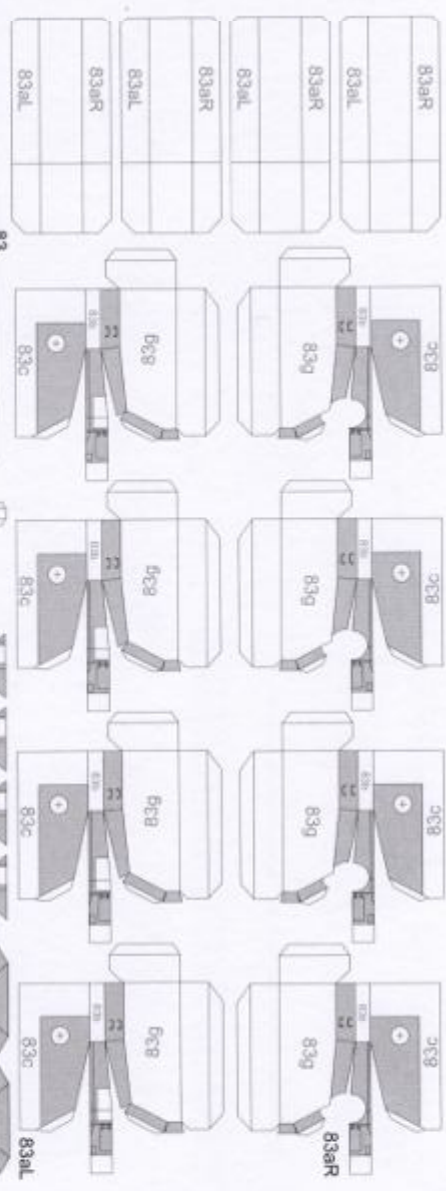

84

